

## N-channel Enhanced mode TO-220F/TO-247 MOSFET

### Features

- High ruggedness
- Low  $R_{DS(ON)}$  (Typ 57.5m $\Omega$ )@ $V_{GS}=10V$
- Low Gate Charge (Typ 69nC)
- Improved dv/dt Capability
- 100% Avalanche Tested
- Application: Charger, LED, PC Power

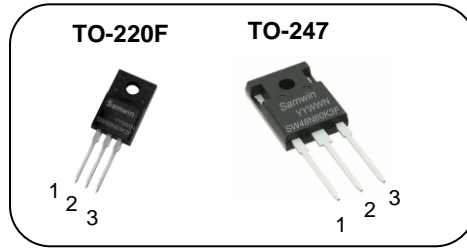

1. Gate 2. Drain 3. Source

$BV_{DSS}$  : 600V  
 $I_D$  : 48A  
 $R_{DS(ON)}$  : 57.5m $\Omega$

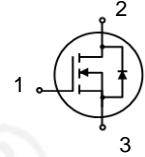

### General Description

This power MOSFET is produced with advanced super junction technology of SAMWIN. This technology enable the power MOSFET to have better characteristics, including fast switching time, low on resistance, low gate charge and especially excellent avalanche characteristics.

### Order Codes

Item	Sales Type	Marking	Package	Packaging
1	SW F 48N60K3F	SW48N60K3F	TO-220F	TUBE
2	SW T 48N60K3F	SW48N60K3F	TO-247	TUBE

### Absolute maximum ratings

Symbol	Parameter	Value		Unit
		TO-220F	TO-247	
$V_{DSS}$	Drain to source voltage	600		V
$I_D$	Continuous drain current (@ $T_C=25^\circ C$ )	48*		A
	Continuous drain current (@ $T_C=100^\circ C$ )	30*		A
$I_{DM}$	Drain current pulsed (note 1)	144		A
$V_{GS}$	Gate to source voltage	$\pm 30$		V
$E_{AS}$	Single pulsed avalanche energy (note 2)	844		mJ
$E_{AR}$	Repetitive avalanche energy (note 1)	80		mJ
dv/dt	MOSFET dv/dt ruggedness(@ $V_{DS}=0\sim 400V$ )	30		V/ns
dv/dt	Peak diode recovery dv/dt (note 3)	20		V/ns
$P_D$	Total power dissipation (@ $T_C=25^\circ C$ )	50	357	W
	Derating factor above 25 $^\circ C$	0.4	2.8	W/ $^\circ C$
$T_{STG}, T_J$	Operating junction temperature & storage temperature	-55 ~ + 150		$^\circ C$
$T_L$	Maximum lead temperature for soldering Purpose, 1/8 from case for 5 seconds	300		$^\circ C$

\*. Drain current is limited by junction temperature.

### Thermal characteristics

Symbol	Parameter	Value		Unit
		TO-220F	TO-247	
$R_{thjc}$	Thermal resistance, Junction to case	2.5	0.35	$^\circ C/W$
$R_{thja}$	Thermal resistance, Junction to ambient	45	33.4	$^\circ C/W$

## Electrical characteristic ( $T_J = 25^\circ\text{C}$ unless otherwise specified )

Symbol	Parameter	Test conditions	Min.	Typ.	Max.	Unit
<b>Off characteristics</b>						
$BV_{DSS}$	Drain to source breakdown voltage	$V_{GS}=0V, I_D=250\mu A$	600			V
$\Delta BV_{DSS} / \Delta T_J$	Breakdown voltage temperature coefficient	$I_D=250\mu A$ , referenced to $25^\circ\text{C}$		0.53		$V/^\circ\text{C}$
$I_{DSS}$	Drain to source leakage current	$V_{DS}=600V, V_{GS}=0V$			9	$\mu A$
		$V_{DS}=480V, T_J=125^\circ\text{C}$		50		$\mu A$
$I_{GSS}$	Gate to source leakage current, forward	$V_{GS}=30V, V_{DS}=0V$			100	nA
	Gate to source leakage current, reverse	$V_{GS}=-30V, V_{DS}=0V$			-100	nA
<b>On characteristics</b>						
$V_{GS(TH)}$	Gate threshold voltage	$V_{DS}=V_{GS}, I_D=250\mu A$	3		5	V
$R_{DS(ON)}$	Drain to source on state resistance	$V_{GS}=10V, I_D=24A, T_J=25^\circ\text{C}$		57.5	68	$m\Omega$
		$V_{GS}=10V, I_D=24A, T_J=125^\circ\text{C}$		122		$m\Omega$
$G_{fs}$	Forward transconductance	$V_{DS}=30V, I_D=24A$		32		S
<b>Dynamic characteristics</b>						
$C_{iss}$	Input capacitance	$V_{GS}=0V, V_{DS}=200V, f=1\text{MHz}$		3517		pF
$C_{oss}$	Output capacitance			85		
$C_{rss}$	Reverse transfer capacitance			3		
$t_{d(on)}$	Turn on delay time	$V_{DS}=300V, I_D=48A, R_G=10\Omega, V_{GS}=10V$ (note 4,5)		43		ns
$t_r$	Rising time			94		
$t_{d(off)}$	Turn off delay time			63		
$t_f$	Fall time			53		
$Q_g$	Total gate charge	$V_{DS}=480V, V_{GS}=10V, I_D=48A$ $I_G=3\text{mA}$ (note 4,5)		69		nC
$Q_{gs}$	Gate-source charge			26		
$Q_{gd}$	Gate-drain charge			28		
$R_g$	Gate resistance	$f=1\text{MHz}$		1.8		$\Omega$

## Source to drain diode ratings characteristics

Symbol	Parameter	Test conditions	Min.	Typ.	Max.	Unit
$I_S$	Continuous source current	Integral reverse p-n Junction diode in the MOSFET			48	A
$I_{SM}$	Pulsed source current				144	A
$V_{SD}$	Diode forward voltage drop.	$I_S=48A, V_{GS}=0V$			1.4	V
$t_{rr}$	Reverse recovery time	$I_S=48A, V_{GS}=0V,$ $di_f/dt=100A/\mu s$		169		ns
$Q_{rr}$	Reverse recovery charge			1.4		$\mu C$

### ※. Notes

1. Repeitative rating : pulse width limited by junction temperature.
2.  $L=30\text{mH}, I_{AS}=7.5A, V_{DD}=50V, R_G=25\Omega$ , Starting  $T_J=25^\circ\text{C}$
3.  $I_{SD} \leq 48A, di/dt = 100A/\mu s, V_{DD} \leq BV_{DSS}$ , Starting  $T_J=25^\circ\text{C}$
4. Pulse Test : Pulse Width  $\leq 300\mu s$ , duty cycle  $\leq 2\%$ .
5. Essentially independent of operating temperature.

**Fig. 1. On-state characteristics**

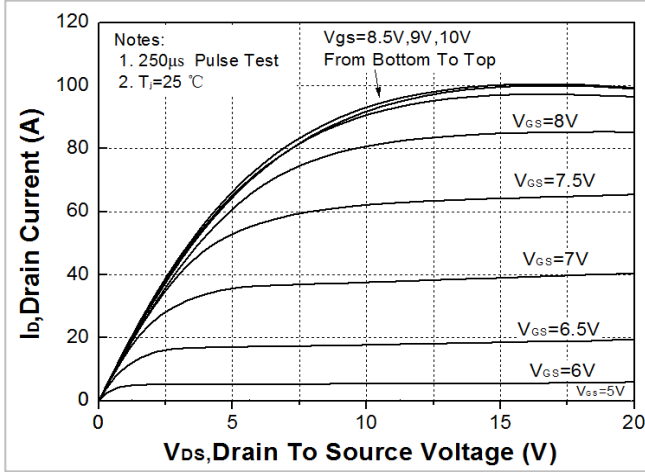

**Fig. 2. Transfer Characteristics**

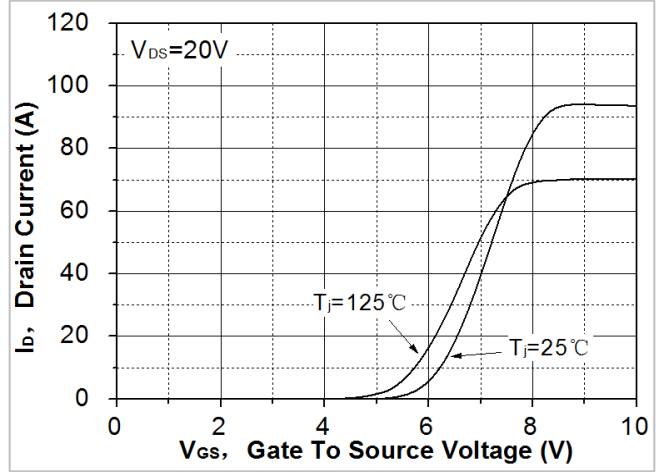

**Fig. 3. On-resistance variation vs. drain current and gate voltage**

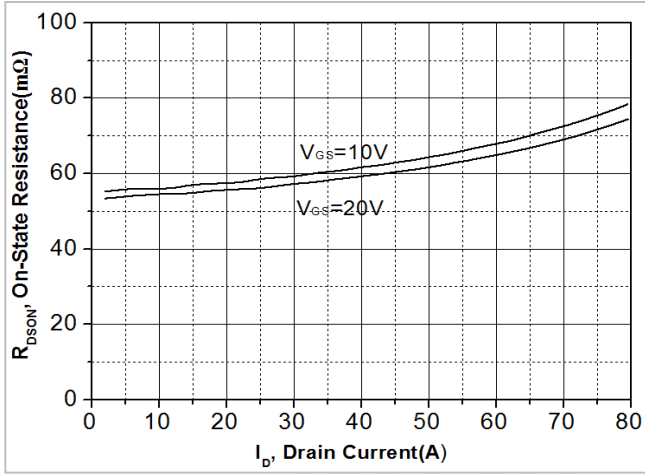

**Fig. 4. On-state current vs. diode forward voltage**

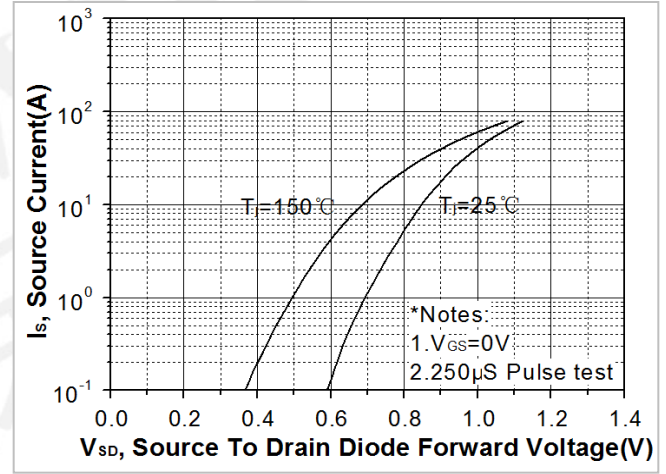

**Fig 5. Breakdown voltage variation vs. junction temperature**

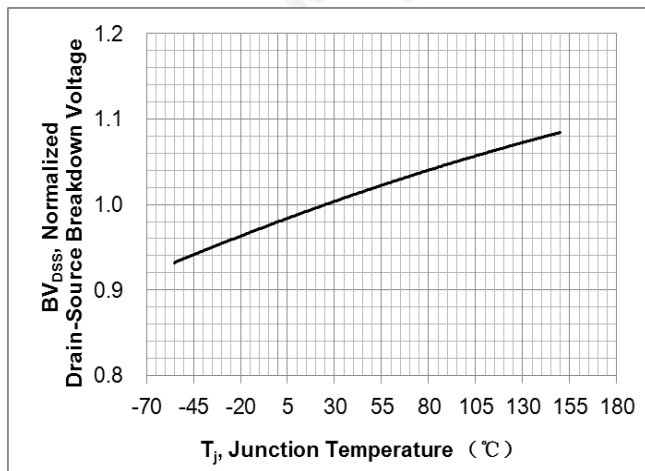

**Fig. 6. On-resistance variation vs. junction temperature**

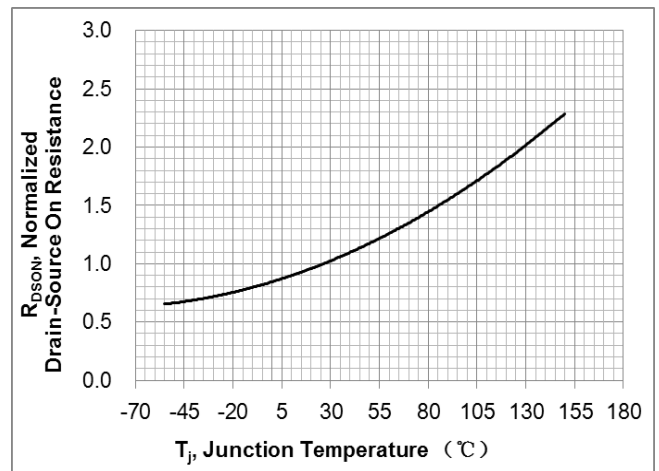

Fig. 7. Gate charge characteristics

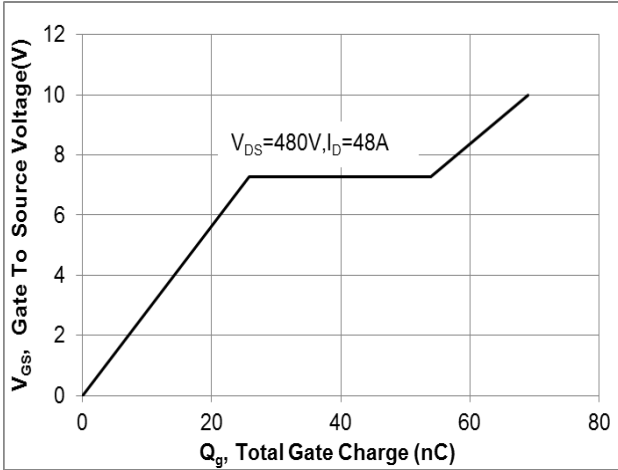

Fig. 8. Capacitance Characteristics

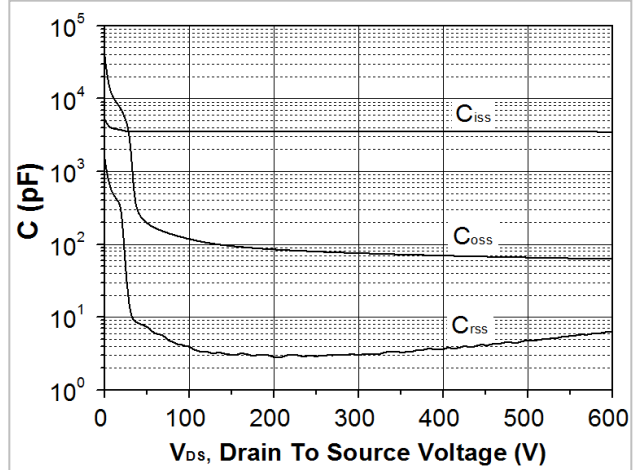

Fig. 9. Maximum safe operating area(TO-220F)

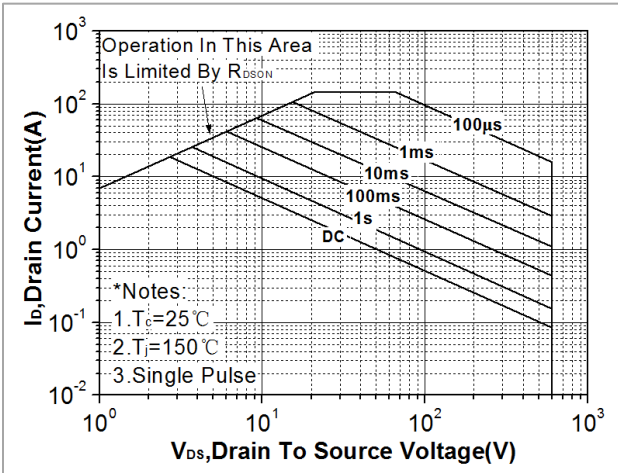

Fig. 10. Maximum safe operating area(TO-247)

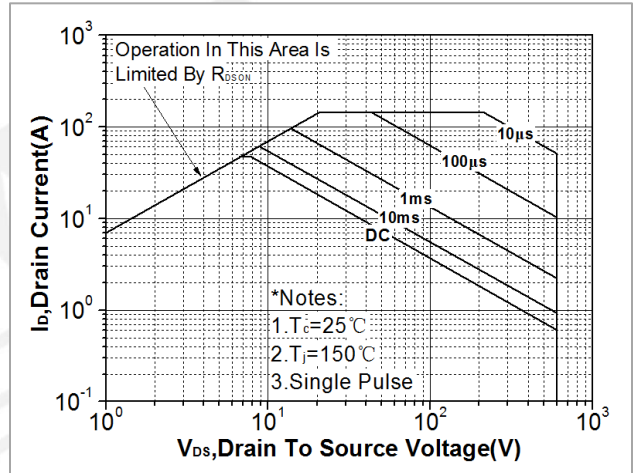

Fig. 11. Transient thermal response curve(TO-220F)

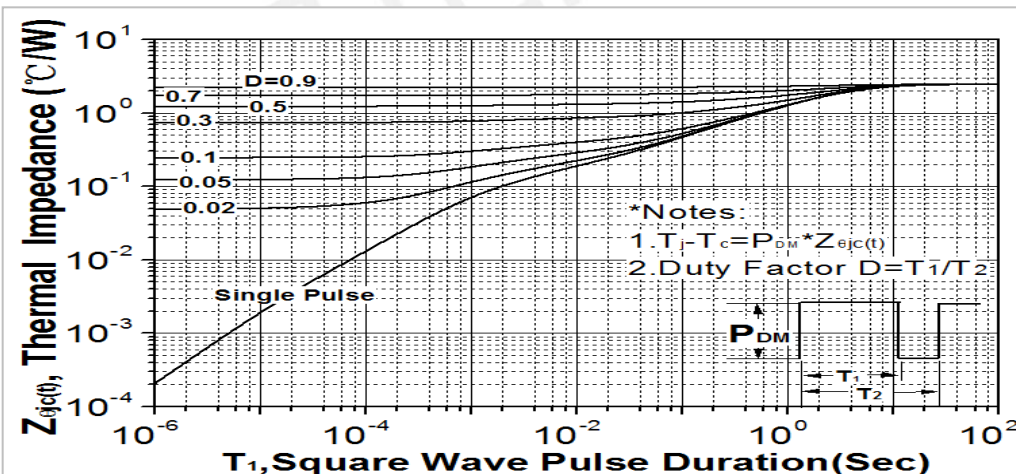

Fig. 12. Transient thermal response curve(TO-247)

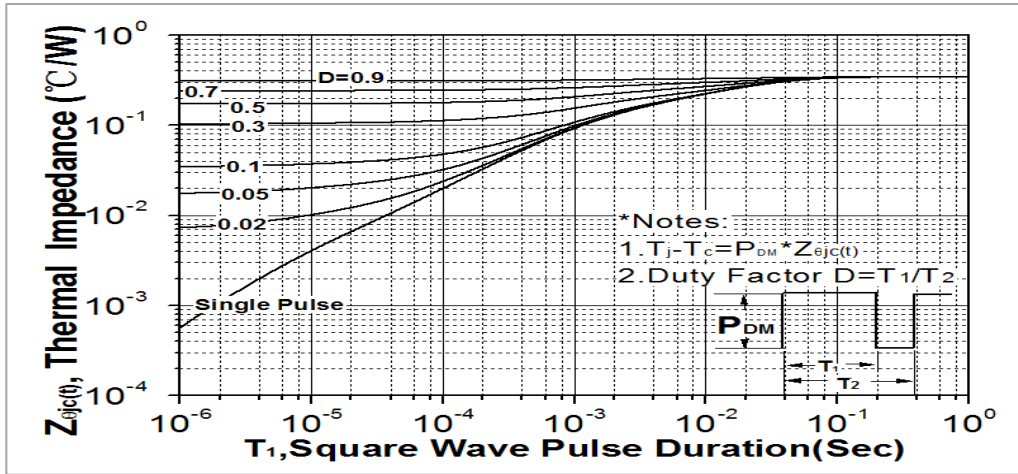

Fig. 13. Gate charge test circuit & waveform

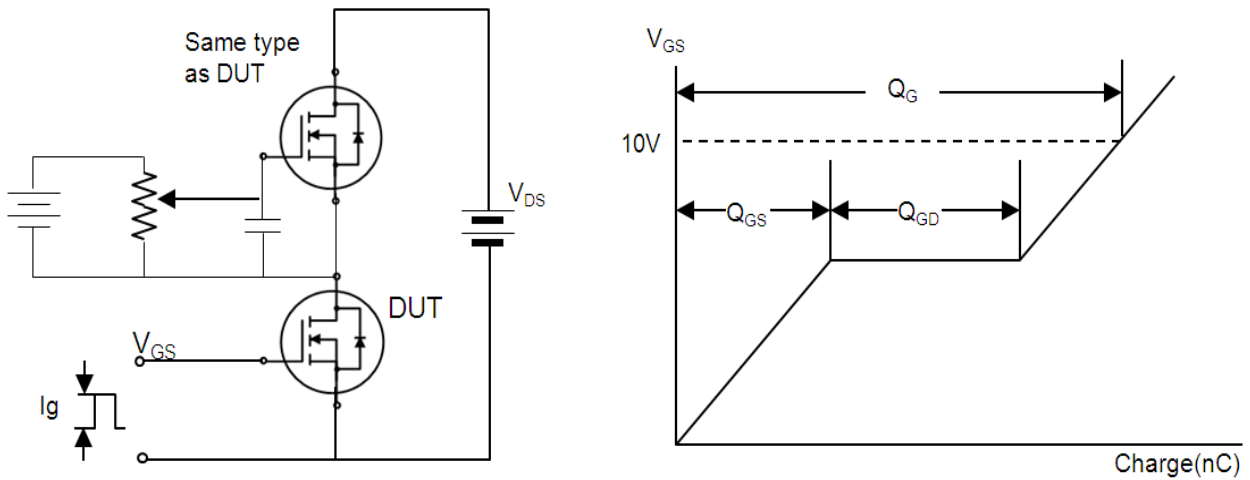

Fig. 14. Switching time test circuit & waveform

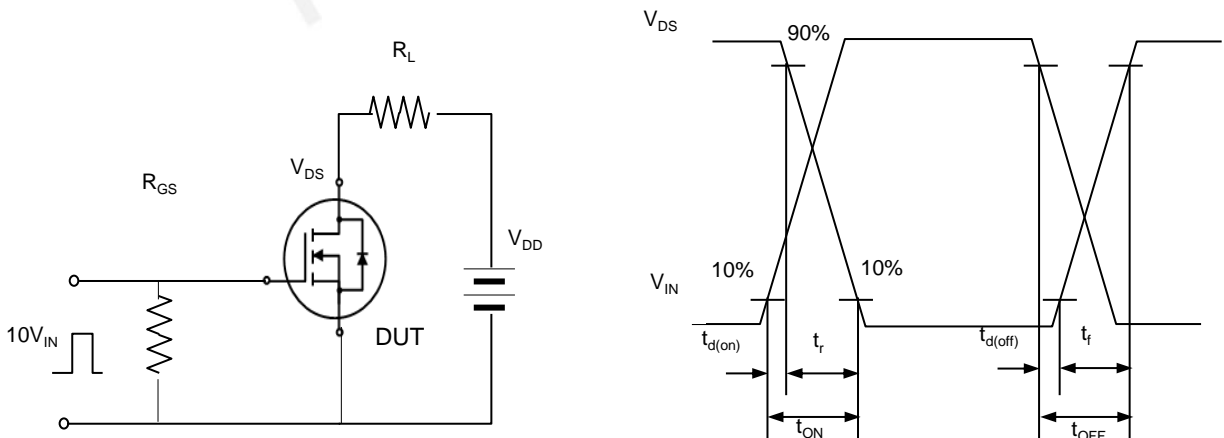

Fig. 15. Unclamped Inductive switching test circuit & waveform

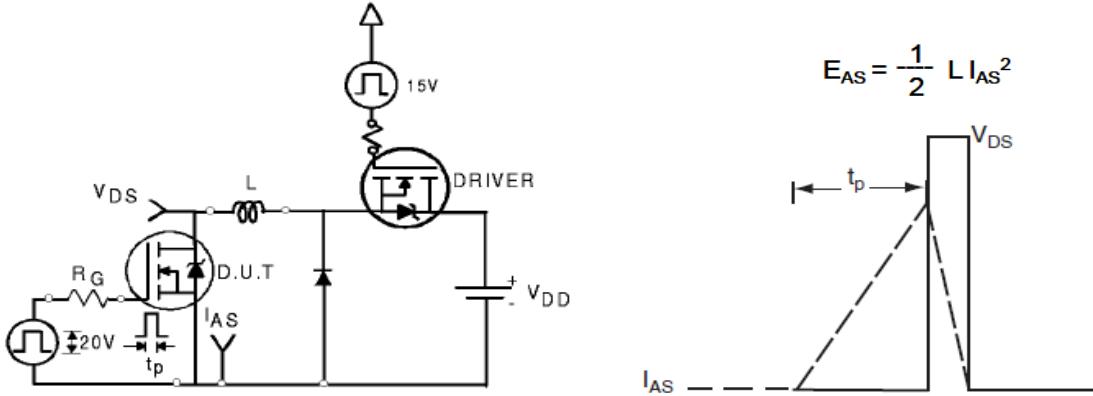
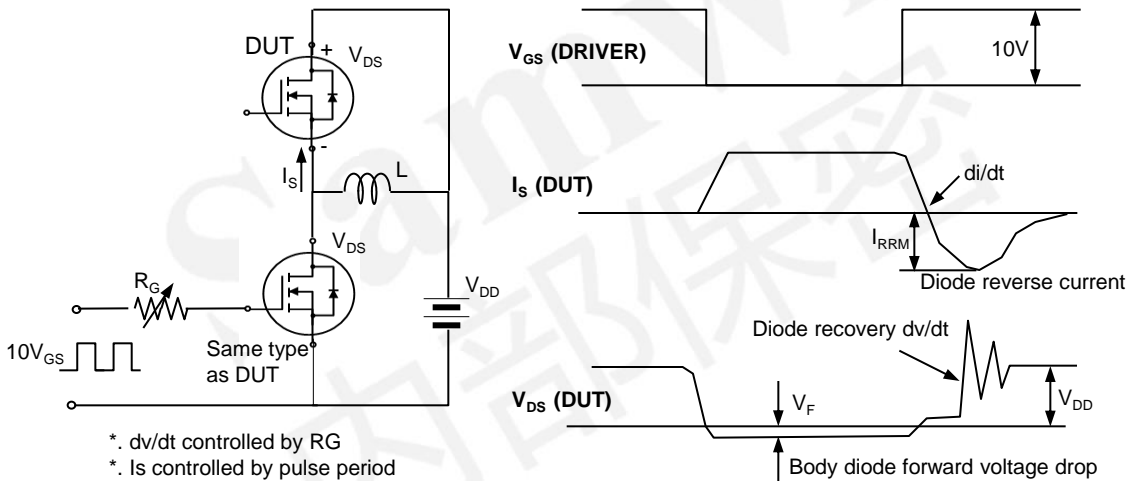



Fig. 16. Peak diode recovery dv/dt test circuit & waveform



## DISCLAIMER

- \* All the data & curve in this document was tested in SEMIPOWER TESTING & APPLICATION CENTER.
- \* This product has passed the PCT,TC,HTRB,HTGB,HAST,PC and Solderdunk reliability testing.
- \* Qualification standards can also be found on the Web site (<http://www.semipower.com.cn>) 
- \* Suggestions for improvement are appreciated, Please send your suggestions to [samwin@samwinsemi.com](mailto:samwin@samwinsemi.com)