

### N-channel Enhanced mode TO-220F MOSFET

#### Features

- High ruggedness
- Low  $R_{DS(ON)}$  (Typ 0.57Ω) @  $V_{GS}=10V$
- Low Gate Charge (Typ 57nC)
- Improved dv/dt Capability
- 100% Avalanche Tested
- Application: LED , Charger, PC Power

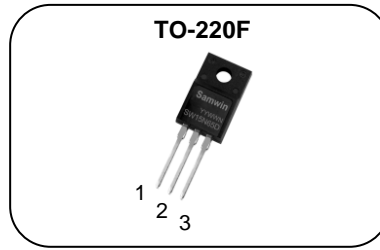

1. Gate 2. Drain 3. Source

$BV_{DSS} : 650V$

$I_D : 15A$

$R_{DS(ON)} : 0.57\Omega$

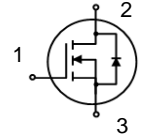

#### General Description

This power MOSFET is produced with advanced technology of SAMWIN.

This technology enable the power MOSFET to have better characteristics, including fast switching time, low on resistance, low gate charge and especially excellent avalanche characteristics.



#### Order Codes

Item	Sales Type	Marking	Package	Packaging
1	SW F 15N65D	SW15N65D	TO-220F	TUBE

#### Absolute maximum ratings

Symbol	Parameter	Value	Unit
$V_{DSS}$	Drain to source voltage	650	V
$I_D$	Continuous drain current (@ $T_C=25^\circ C$ )	15*	A
	Continuous drain current (@ $T_C=100^\circ C$ )	9.5*	A
$I_{DM}$	Drain current pulsed (note 1)	60	A
$V_{GS}$	Gate to source voltage	$\pm 30$	V
$E_{AS}$	Single pulsed avalanche energy (note 2)	263	mJ
$E_{AR}$	Repetitive avalanche energy (note 1)	25	mJ
dv/dt	Peak diode recovery dv/dt (note 3)	5	V/ns
$P_D$	Total power dissipation (@ $T_C=25^\circ C$ )	33	W
	Derating factor above 25°C	0.26	W/°C
$T_{STG}, T_J$	Operating junction temperature & storage temperature	-55 ~ + 150	°C
$T_L$	Maximum lead temperature for soldering purpose, 1/8 from case for 5 seconds.	300	°C

\*. Drain current is limited by junction temperature.

#### Thermal characteristics

Symbol	Parameter	Value	Unit
$R_{thjc}$	Thermal resistance, Junction to case	3.8	°C/W
$R_{thja}$	Thermal resistance, Junction to ambient	49	°C/W

## Electrical characteristic ( $T_C = 25^\circ\text{C}$ unless otherwise specified )

Symbol	Parameter	Test conditions	Min.	Typ.	Max.	Unit
<b>Off characteristics</b>						
$BV_{DSS}$	Drain to source breakdown voltage	$V_{GS}=0V, I_D=250\mu A$	650			V
$\Delta BV_{DSS} / \Delta T_J$	Breakdown voltage temperature coefficient	$I_D=250\mu A$ , referenced to $25^\circ\text{C}$		0.68		$V/^\circ\text{C}$
$I_{DSS}$	Drain to source leakage current	$V_{DS}=650V, V_{GS}=0V$			1	$\mu A$
		$V_{DS}=520V, T_C=125^\circ\text{C}$			50	$\mu A$
$I_{GSS}$	Gate to source leakage current, forward	$V_{GS}=30V, V_{DS}=0V$			100	nA
	Gate to source leakage current, reverse	$V_{GS}=-30V, V_{DS}=0V$			-100	nA
<b>On characteristics</b>						
$V_{GS(TH)}$	Gate threshold voltage	$V_{DS}=V_{GS}, I_D=250\mu A$	2.5		4.5	V
$R_{DS(ON)}$	Drain to source on state resistance	$V_{GS}=10V, I_D=7.5A$		0.57	0.72	$\Omega$
$G_{fs}$	Forward transconductance	$V_{DS}=30V, I_D=7.5A$		13		S
<b>Dynamic characteristics</b>						
$C_{iss}$	Input capacitance	$V_{GS}=0V, V_{DS}=25V, f=1\text{MHz}$		2646		pF
$C_{oss}$	Output capacitance			195		
$C_{rss}$	Reverse transfer capacitance			18		
$t_{d(on)}$	Turn on delay time	$V_{DS}=325V, I_D=15A, R_G=25\Omega, V_{GS}=10V$ (note 4,5)		35		ns
$t_r$	Rising time			58		
$t_{d(off)}$	Turn off delay time			117		
$t_f$	Fall time			50		
$Q_g$	Total gate charge	$V_{DS}=520V, V_{GS}=10V, I_D=15A, I_g=4mA$ (note 4,5)		57		nC
$Q_{gs}$	Gate-source charge			15		
$Q_{gd}$	Gate-drain charge			23		
$R_g$	Gate resistance		$V_{DS}=0V$ , Scan F mode		1.0	

## Source to drain diode ratings characteristics

Symbol	Parameter	Test conditions	Min.	Typ.	Max.	Unit
$I_S$	Continuous source current	Integral reverse p-n Junction diode in the MOSFET			15	A
$I_{SM}$	Pulsed source current				60	A
$V_{SD}$	Diode forward voltage drop.	$I_S=15A, V_{GS}=0V$			1.4	V
$t_{rr}$	Reverse recovery time	$I_S=15A, V_{GS}=0V,$ $dI_F/dt=100A/\mu s$		499		ns
$Q_{rr}$	Reverse recovery charge				6.3	$\mu C$

### ※. Notes

1. Repeattive rating : pulse width limited by junction temperature.
2.  $L = 2.33\text{mH}$ ,  $I_{AS} = 15A$ ,  $V_{DD} = 50V$ ,  $R_G = 25\Omega$ , Starting  $T_J = 25^\circ\text{C}$
3.  $I_{SD} \leq 15A$ ,  $dI/dt = 100A/\mu s$ ,  $V_{DD} \leq BV_{DSS}$ , Starting  $T_J = 25^\circ\text{C}$
4. Pulse Test : Pulse Width  $\leq 300\mu s$ , duty cycle  $\leq 2\%$ .
5. Essentially independent of operating temperature.

**Fig. 1. On-state characteristics**

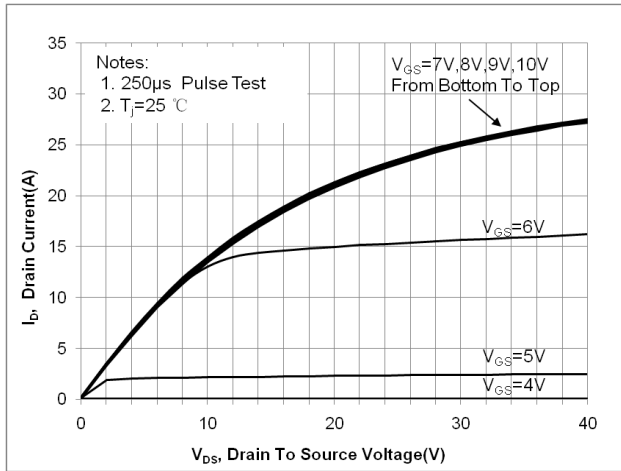

**Fig. 2. Transfer Characteristics**

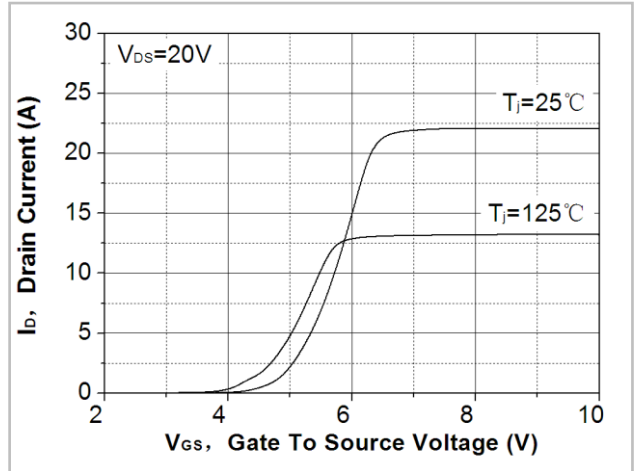

**Fig. 3. On-resistance variation vs. drain current and gate voltage**

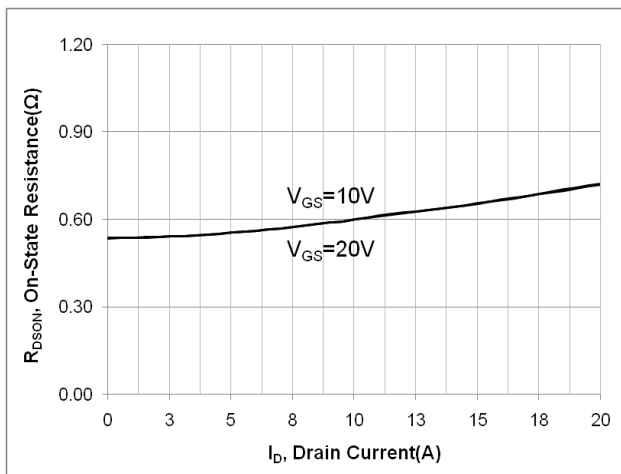

**Fig. 4. On-state current vs. diode forward voltage**

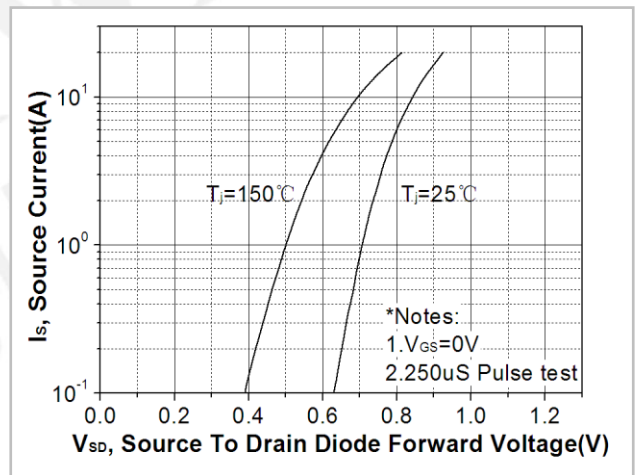

**Fig 5. Breakdown voltage variation vs. junction temperature**

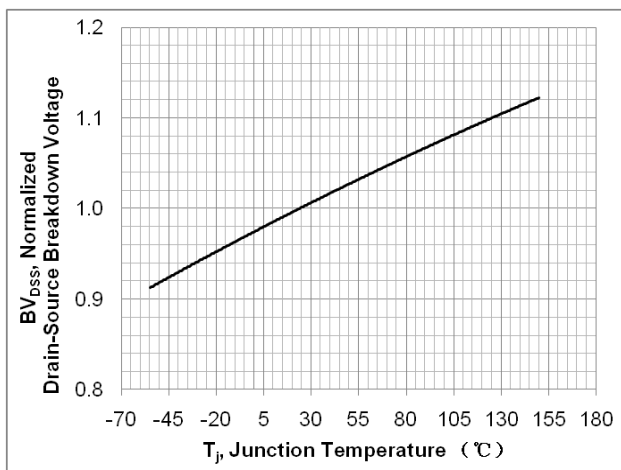

**Fig. 6. On-resistance variation vs. junction temperature**

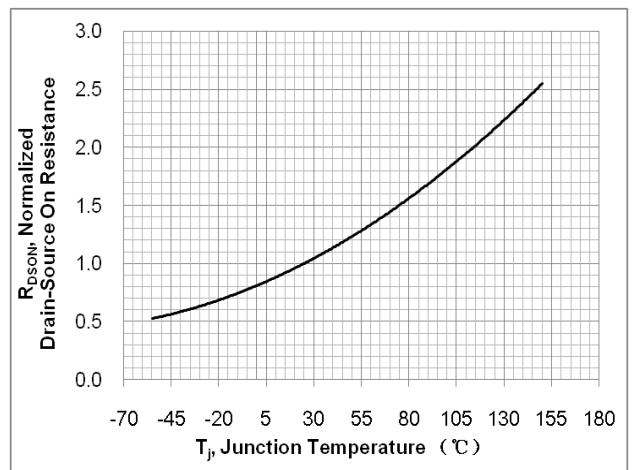

Fig. 7. Gate charge characteristics

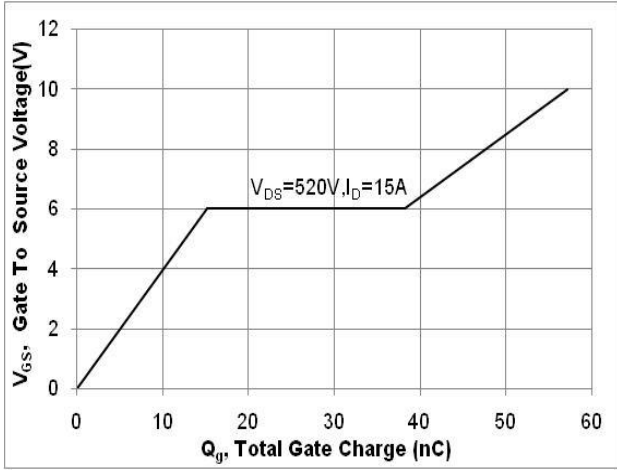

Fig. 8. Capacitance Characteristics

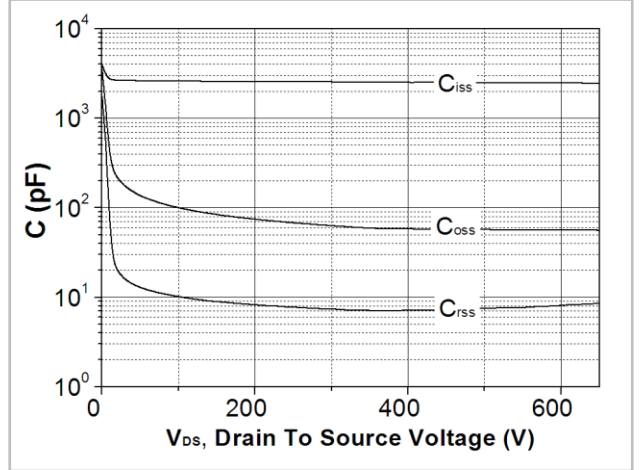

Fig. 9. Maximum safe operating area

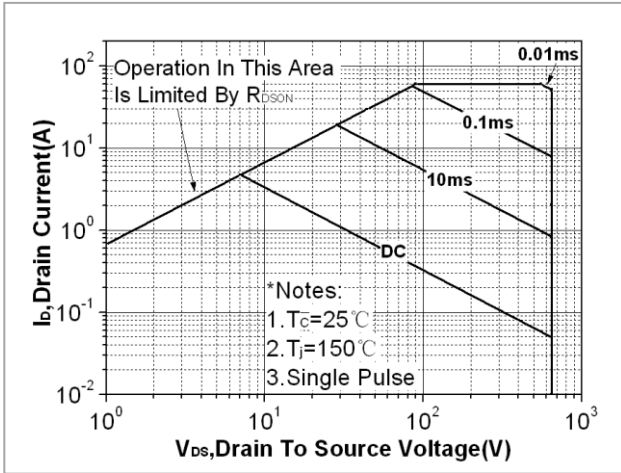

Fig. 10. Transient thermal response curve

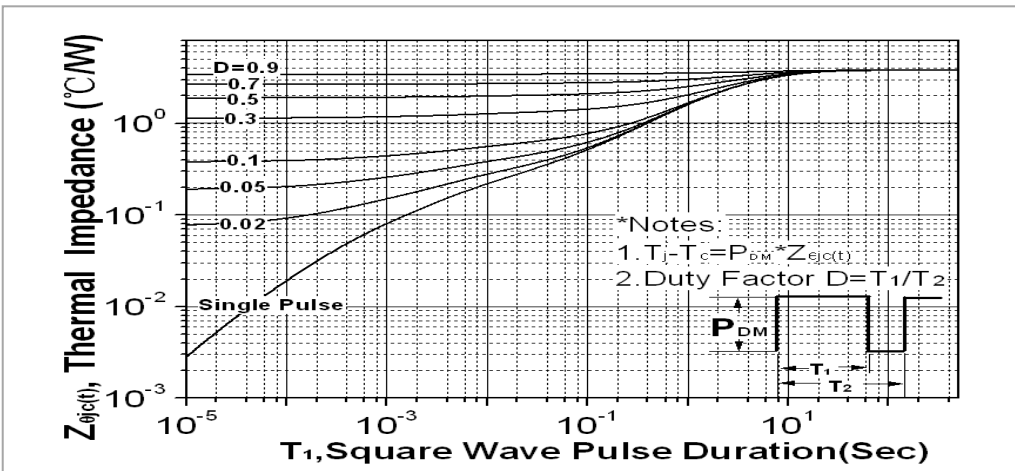

Fig. 11. Gate charge test circuit & waveform

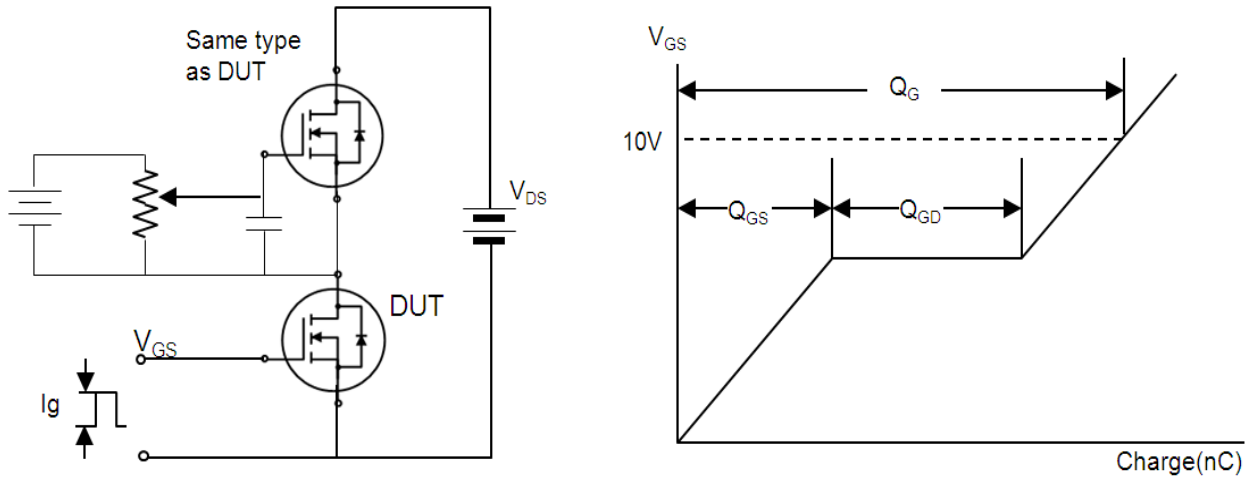

Fig. 12. Switching time test circuit & waveform

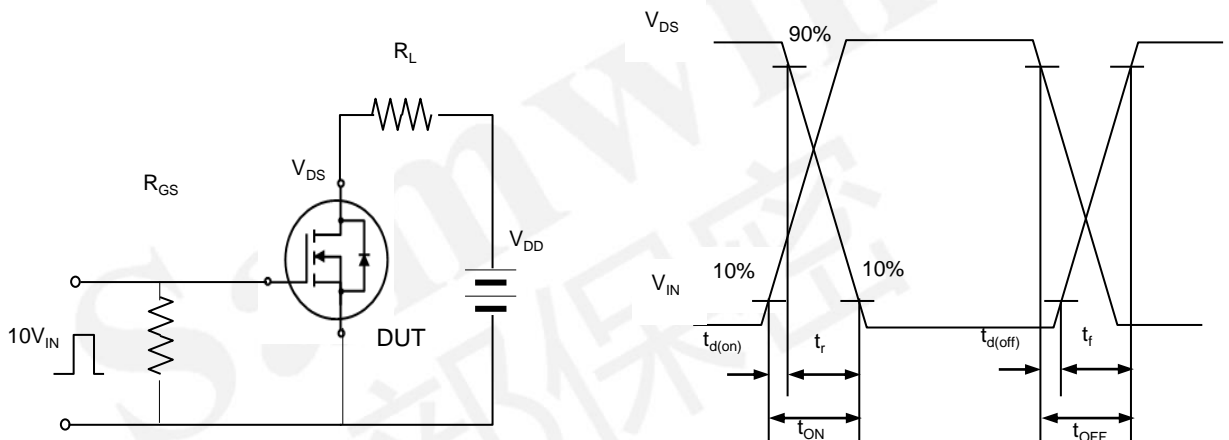

Fig. 13. Unclamped Inductive switching test circuit & waveform

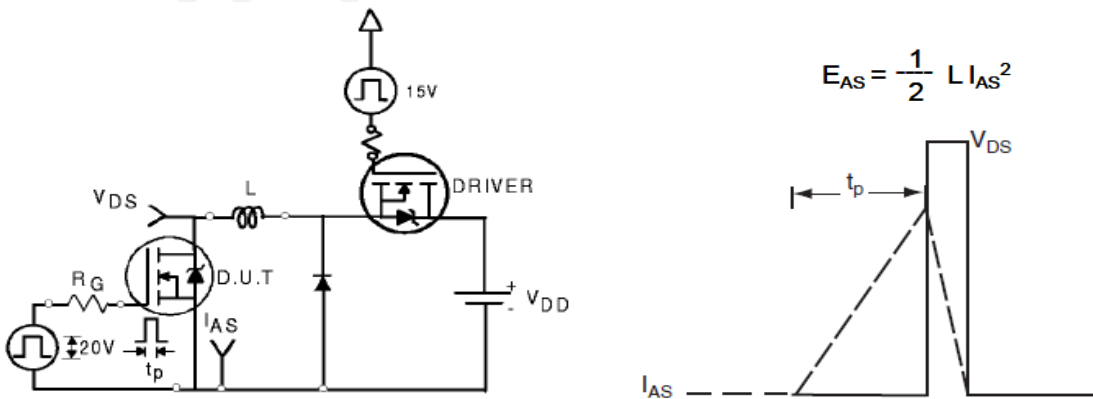
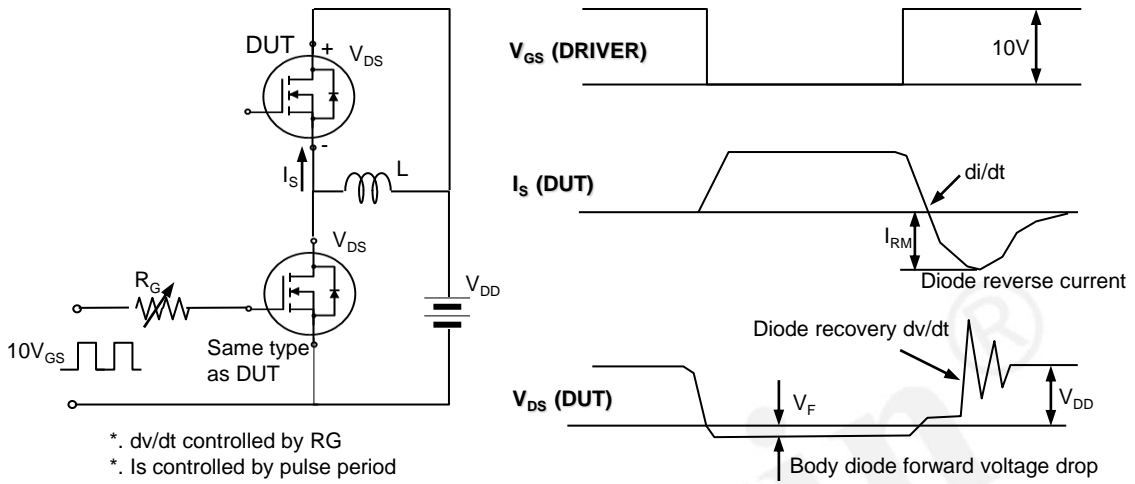



Fig. 14. Peak diode recovery dv/dt test circuit & waveform



### DISCLAIMER

- \* All the data & curve in this document was tested in SEMIPOWER TESTING & APPLICATION CENTER.
- \* This product has passed the PCT,TC,HTRB,HTGB,HAST,PC and Solderdunk reliability testing.
- \* Qualification standards can also be found on the Web site (<http://www.semipower.com.cn>) 
- \* Suggestions for improvement are appreciated, Please send your suggestions to [samwin@samwinsemi.com](mailto:samwin@samwinsemi.com)